



**CEILINGS.
ELEVATED IDEAS.**

HAYER & BOECKER



DIE DRAHTWEBER

WEAVING IDEAS.



Architectural Wire Cloth for

- Panels, drapes or framed-elements
- Integrated lighting systems
- Acoustic systems
- Disguising technical services
- Fire protection

Haver & Boecker began producing woven wire cloth in Hohenlimburg, Germany, in 1887. Today, we are one of the world's leading wire weaving companies with a global network of branches and manufacturing facilities. Our work is based upon experience,

continuous research and development of products and manufacturing processes, along with the knowledge and ability of our employees. This combination of tradition and innovation allows us to meet and exceed the high expectations of our customers.

We offer architects and designers a broad range of wire cloth specifications for highly aesthetic and yet functional ceiling designs.

Differing visual effects can be achieved depending on the choice of specification, in combination with the lighting and environment, making the material appear shiny and bright, translucent, opaque, cool and elegant or warm and discreet. Whether supplied as flat panels, convex or concave profiles, or as cassettes, woven wire cloth can be used to enhance large or small areas. Along with its aesthetic qualities, woven wire cloth can also help improve the acoustics of a building and conceal service equipment such as air conditioning or sprinkler systems and yet remain effective as a result of the woven wire cloth's open area.

Fabricated from selected high quality materials and cleaned using our special final cleaning process our woven wire cloth is durable, robust and non-flammable and meets fire protection criteria for buildings.

**Challenge:**

Together we identify the specific project requirements in terms of form, shape and function.

**Development:**

Our team of specialists addresses construction and detail requirements and submits initial solutions.

**Detail planning:**

With our experience and knowledge all aspects of the project are brought together.

**Production:**

Precision workmanship using state-of-the-art technology and machinery from start to finish.

**Installation:**

Qualified logistic partners and installation teams guarantee perfect and on-time installation of Haver & Boecker Architectural Wire Cloth.

**After Sales Service:**

Cooperation does not end with the completion of a project; it extends into the future with continued support and advice.

STEP BY STEP TOWARDS YOUR SUCCESS.

Haver & Boecker's process chain provides maximum transparency, flexibility and quality to realize your plans. Through every step of the project a diverse group of specialists is there to support you: The interaction of creativity and technology gives your idea its own individuality.

Not only do you have the confidence of continuous professional service, you also have the possibility to explore new aspects of your design in greater depth, giving you the opportunity to bring new ideas into the process at any given point in time.



Architect: J.S.K. Architekten, D-Francfort

Type of weave: DOKAWELL-MONO 8965

Application: Ceiling Design



WEAVING INNOVATIVE SOLUTIONS.

AIRPORT DÜSSELDORF

Following the fire at Düsseldorf Airport in 1996 the new Check-in-Hall and Gate B were subsequently rebuilt using high quality fire retardant materials. The "airport 2000 plus" project has created a new terminal that combines service performance and a unique architectural experience.

The stainless steel wire cloth ceiling creates an exclusive ambience whilst at the same time is functional in concealing technical installations such as sprinklers without reducing effectiveness. Each woven wire cloth element was checked in our factory to give a consistent drape. The elements are fixed using slotted profiles and can be easily moved for access and maintenance.

Haver & Boecker developed the fixing system and supplied ready-to-install fabricated elements. Complex parts lists, stating all special elements, too, guaranteed a smooth handling.

CHALLENGE

- Regular sag of all elements
- Non-flammable material with a minimum of 70 % open area allowing unrestricted function of the sprinklers
- Easy to handle by one person

SOLUTION

- Sag control for each element
- Development of a weave type with 75 % open area
- Design and development of sliding mechanism with slotted profiles: To gain access, the wire cloth elements are removed from the locking device and moved on the ceiling sub-structure





IMPROVING ACOUSTICS.

Together with state-of-the-art acoustic fleece Haver & Boecker woven wire cloth offers brilliant sound absorbing effects. The acoustic material is concealed behind high-quality stainless steel mesh creating a sophisticated and elegant ambience.

Architect: Sir Norman Foster, GB-London

Type of weave:
Plenary

Assembly Hall: DOKA-MONO 7021

Press Lobby: DOKA-MONO 1601

Application: Ceiling Design



**PLENARY ASSEMBLY HALL
AND PRESS LOBBY OF
THE REICHSTAG, BERLIN
(GERMANY)**



Haver & Boecker delivered pre-fabricated elements to be installed by the metal-worker.

CHALLENGE

- Discreet optical design
- Supports for the cooling ceiling and the acoustic
- Adjustment to the round building shape

SOLUTION

- Trapezoidal framed elements of pre-tensioned wire cloth



Architect: Joppien & Dietz,
D-Francfort

Type of weave: ECLA-MONO 4391

Application: Ceiling Design



RAPID TRANSIT STATION, HANNOVER (GERMANY)

Haver & Boecker delivered the ready-to-install elements and provided on-site installation assistance.

CHALLENGE

- Panelling of large ceiling surfaces with non visible sag
- Removable in some areas
- Consideration of the polygonal shape of the building

SOLUTION

- Tensioned single length elements with intermediate support
- Movable cassette elements
- Bespoke elements to suit polygonal construction



PRINT MEDIA ACADEMY, HEIDELBERG (GERMANY)

Haver & Boecker manufactured cut-to-size elements ready for fabrication and installation.

CHALLENGE

- Panelling of the oval lecture hall

SOLUTION

- Single cassette elements
- Integration of acoustic material

Architect: Planungsgruppe Heidelberg,
D-Heidelberg

Type of weave: DETENTION 7016

Application: Ceiling Design / Acoustics

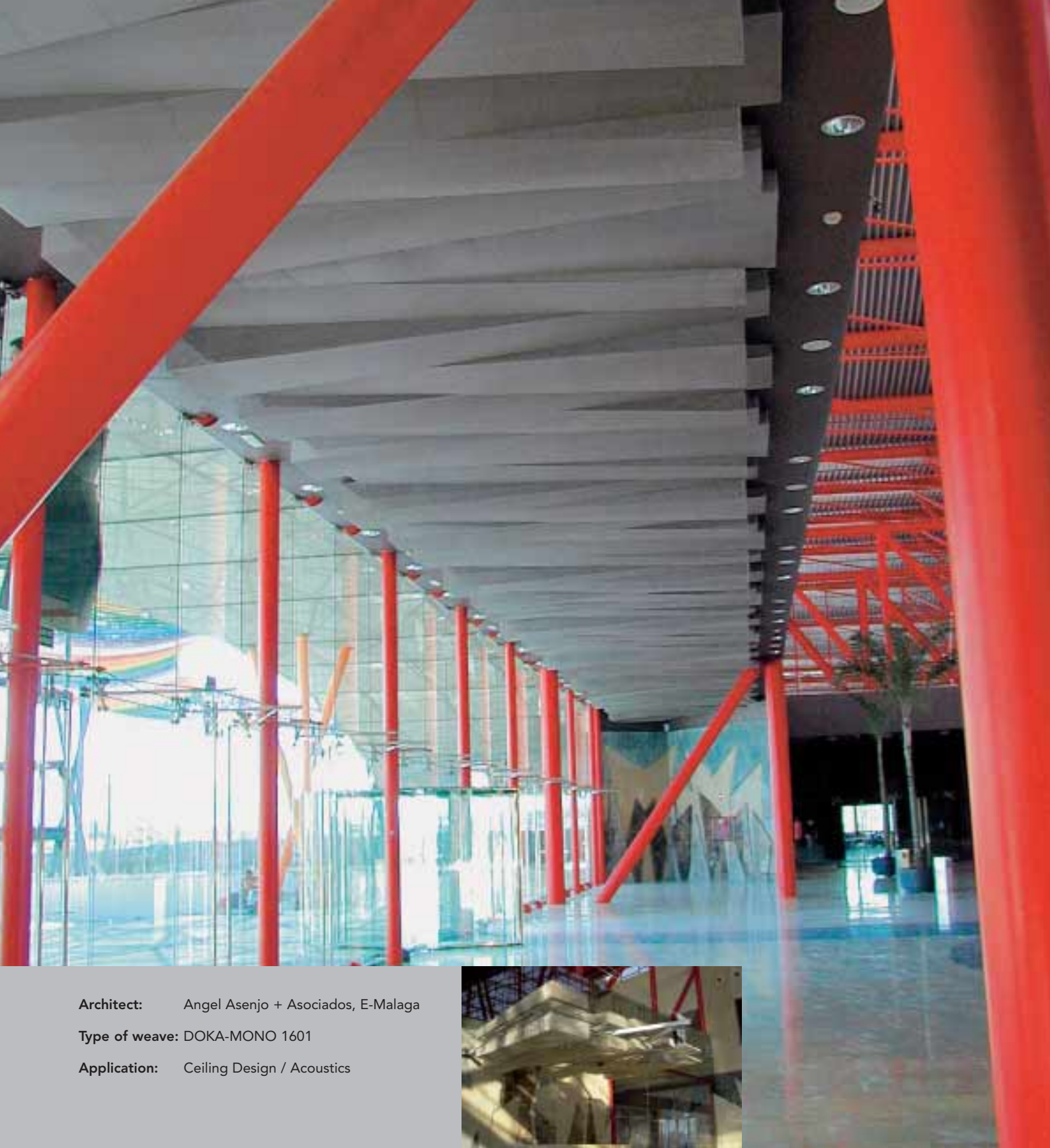

Architect: Angel Asenjo + Asociados, E-Malaga

Type of weave: DOKA-MONO 1601

Application: Ceiling Design / Acoustics



EXHIBITION AND CONFERENCE CENTRE MALAGA

CHALLENGE

- Continuity of the architectural concept at the entrance
- Improvement of the room acoustics

SOLUTION

- Ready-to-install trapezoidal cassette-elements
- Integrated acoustic material
- Lighting islands
- Development of bespoke fixing system





SUN PROTECTION.

Woven wire cloth has a precisely defined open area that facilitates the creation of attractive yet highly effective sun protection systems. Our wide range of mesh specifications offers many durable design possibilities that can be integrated into nearly every architectural concept for both internal and external applications.

Architect: Prof. Bofinger & Partner and Martin Heiderich, D-Wiesbaden

Type of weave: DOKAWELL-MONO 3021

Application: Ceiling Design / Sun Protection

CHALLENGE

- Sun protection beneath the glass ceiling
- Integration of lighting
- Implementation including oval edge detail

SOLUTION

- Tensioning of single elements using the Haver & Boecker tension strip and clevis screw fixing system
- Bespoke fixing solution to create the oval edge
- Aesthetic cut-outs to accommodate suspended lighting

BUS STATION OSNABRÜCK (GERMANY)

Haver & Boecker conducted on-site measuring, manufacturing, fabrication and installation of the wire cloth elements.



Architect: Heiderich-Hummert-Klein
Architekten, D-Dortmund

Type of weave: DOKAWELL-MONO 8967

Application: Ceiling Design / Sun Protection

BUS STATION HERNE (GERMANY)

Haver & Boecker provided engineering drawings during the concept phase, delivery and installation of the wire cloth elements.

MESHES. WAITING FOR YOUR IDEAS.



ECLA-MONO 4391

G^1 (kg/m ²)	A_o^2 (%)
6.2	52



ECLA-TWIN 4243

G^1 (kg/m ²)	A_o^2 (%)
5.4	57

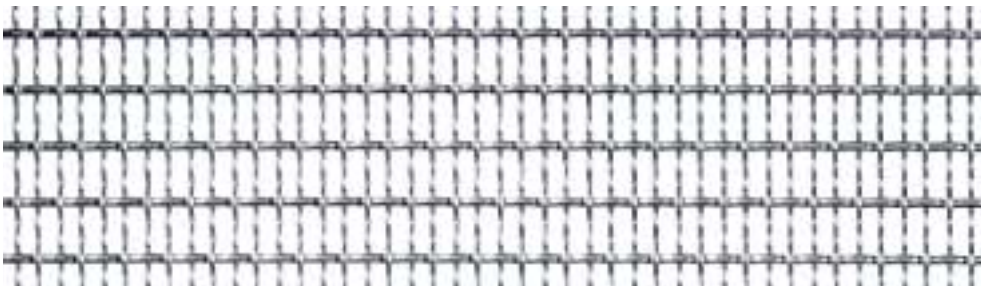

DOKAWELL-MONO 3001

G^1 (kg/m ²)	A_o^2 (%)
3.2	56



MULTI-BARRETTE 8130

G^1 (kg/m ²)	A_o^2 (%)
10.2	46

¹⁾ G=Weight, ²⁾ A_o=Open Area

ARCHITECTURAL WIRE CLOTH

Architecture presents itself in many forms. We have developed a wide range of meshes to cover the diverse nature of the applications. The choice of warp and weft wire generates many different patterns each with specific optical features. The use of

different materials and surface treatments can create brilliant, shimmering or even coloured finishes to the mesh.

The examples are a representative selection of some of our standard weave types on a scale of 1:1. Of

course we do develop individual types of weave, too.

Please visit our website at www.weavingideas.com where you will find further information and images of Haver & Boecker Architectural Wire Cloth.

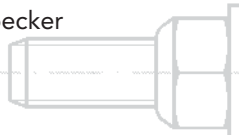

SOLUTIONS. TECHNOLOGY FOR YOUR IDEAS.

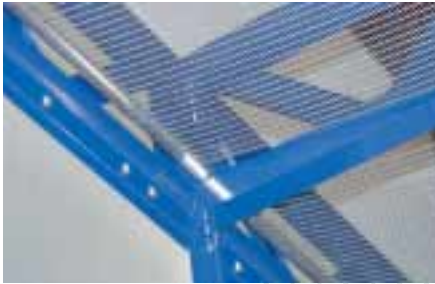

Wire cloth edged using slotted profiles. Locked into position at the sub-structure

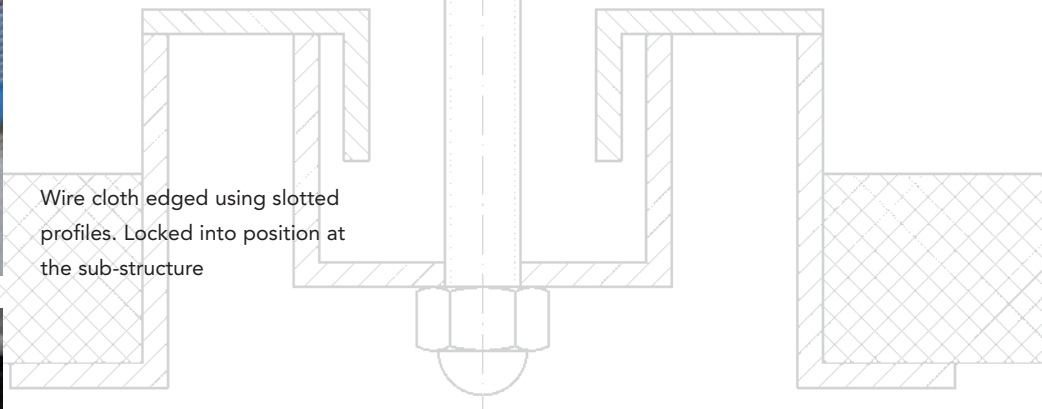

Open position of a woven wire cloth element edged with slotted profiles



Woven wire cloth elements tensioned using tension profile and clevis screw system



Detail showing integrated lighting

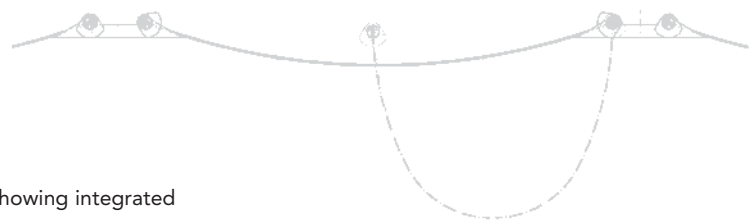

TENSIONING SYSTEMS

We have developed a number of tensioning systems and edging details to ensure technical and optical integration of wire cloth elements with the ceiling. These offer a smooth and problem free installa-

tion whilst ensuring optimum performance of the structure.

This page shows some of the most common fixing methods.

Please visit our website at www.weavingideas.com where

you will find further information about Haver & Boecker Architectural Wire Cloth and tensioning systems.

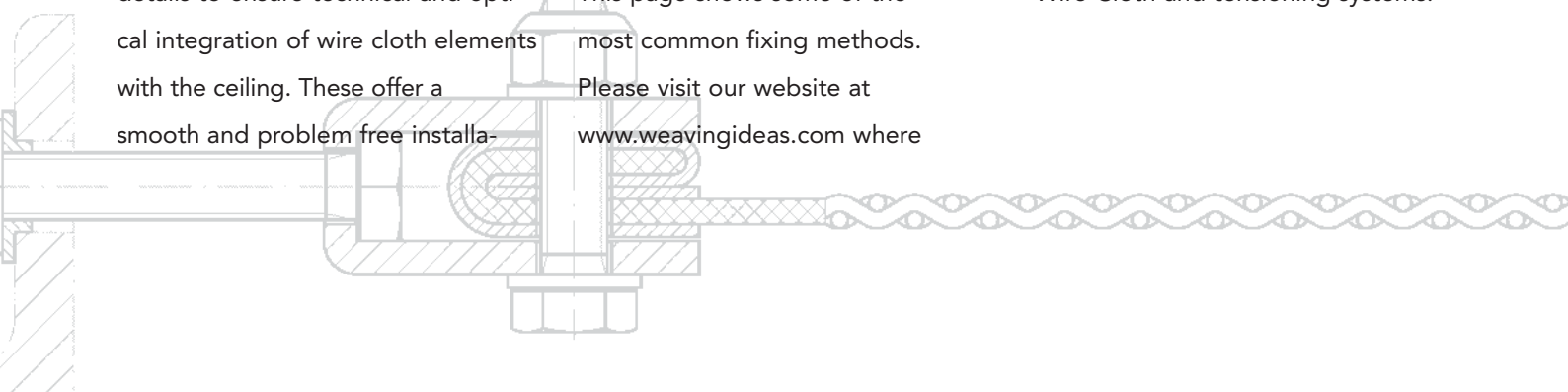

Belgium:

HAYER BELGIUM S.A.

Rue des Gaillettes 9
B-4651 BATTICE
Téléphone: 087-69 29 60
Fax: 087-69 29 61
E-Mail: hbsa@cybernet.be

France:

HAYER & BOECKER Toiles Métalliques

115, rue neuve d'Argenson
F-24100 BERGERAC
Téléphone: 5-53 24 93 13
Fax: 5-53 24 95 99
E-Mail: haver.toiles@wanadoo.fr

Spain:

HAYER & BOECKER Telas Metalicas

Avda. Les Bobiles, 7
Casa 2
E-08850 GAVA (Barcelona)
Teléfono: 93-6 62 63 55
Fax: 93-6 62 90 59
E-Mail: haverboecker@telefonica.net

Great Britain:

H&B Wire Fabrications Ltd.

30-32 Tatton Court
Kingsland Grange, Woolston
GB-WARRINGTON, Cheshire WA1 4RR
Phone: 01925-81 95 15
Fax: 01925-83 17 73
E-Mail: sales@hbwf.co.uk
Internet: www.hbwf.co.uk

U.S.A.:

W.S. TYLER – Wire Cloth Products

8570 Tyler Boulevard
USA-MENTOR, Ohio 44060
Phone: 440-974-1047 + 800-321-6188
Fax: 440-974-0921
E-Mail: wstyler@wstyler.com
Internet: www.wstyler.com

Canada:

W.S. TYLER CANADA LTD.

225 Ontario Street
CAN-ST. CATHARINES, Ontario L2R 7B6
Phone: 905-688-2644 + 800-325-5993
Fax: 905-688-4733
E-Mail: wstsales@wstyler.on.ca
Internet: www.wstyler.on.ca

HAYER & BOECKER



DIE DRAHTWEBER

HAYER & BOECKER
Ennigerloher Straße 64
D-59302 OELDE
Germany

Phone: +49-(0) 25 22-30 684
Fax: +49-(0) 25 22-30 767
E-Mail: architektur@haverboecker.com
Internet: www.weavingideas.com